

SwitchDoc Labs

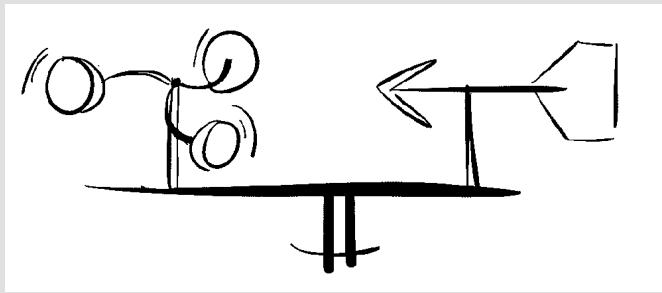

The **PiWeather Board** is an interface board for connecting a full featured, customizable Weather Station board for Raspberry Pi and Arduino projects. It contains a built in I2C BME680 Barometer/Temperature/Humidity/Air Quality sensor as well as a 4 channel I2C Mux based on the TCA9545.

It also has a built-in SwitchDoc Labs WeatherRack interface for the the Anemometer/Wind Vane/Rain Bucket.

Features and Benefits:

- Provides an excellent interface for a Weather Station hookup to Raspberry Pi or Arduino
- Supports Grove Connectors
- Includes 4 channel I2C Mux based on the TCA9545
- Includes Arduino and Raspberry Pi Software
- Supports SwitchDoc Labs WeatherRack Wind Vane / Anemometer / Rain Bucket
- Contains I2C BME680 Barometer / Temperature / Humidity / Air Quality sensor
- Directly powered from Raspberry Pi / Arduino
- Works with Raspberry Pi (3.3V) GPIO and Arduino (5.0V) GPIO as well as the 5.0V Pi2Grover Board
- Low Cost
- Full Test Code Supplied
- Quantity Discounts Available
- Immediate Availability

Introduction

The **PiWeather Board** is a weather station controller board designed to interface to Arduino and Raspberry Pi computers. It is an interface board developed by SwitchDoc Labs to allow the user to easily build a fully functioned Weather Station while allowing customization of functions.

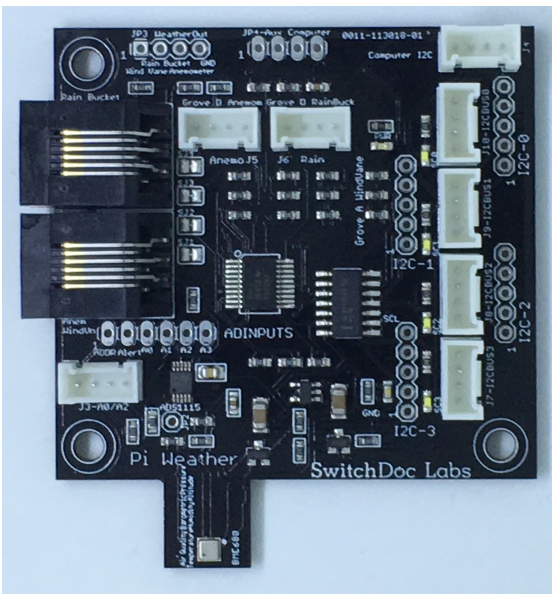

The PiWeather Board is derived from Project Curacao. Generation 1 of this board was deployed and tested on the island nation of Curacao before Generation 2 was released to production. We then added support for Grove Connectors and the 4 channel I2C Mux to support large combinations of sensors such as in SkyWeather.

Combine the PiWeather Board with a SunAir or SunAirPlus board to create a solar powered weather station.

Additional code and examples on shop.switchdoc.com on the PiWeather Board Product Page

Block Diagram

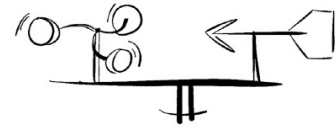

The PiWeather Board

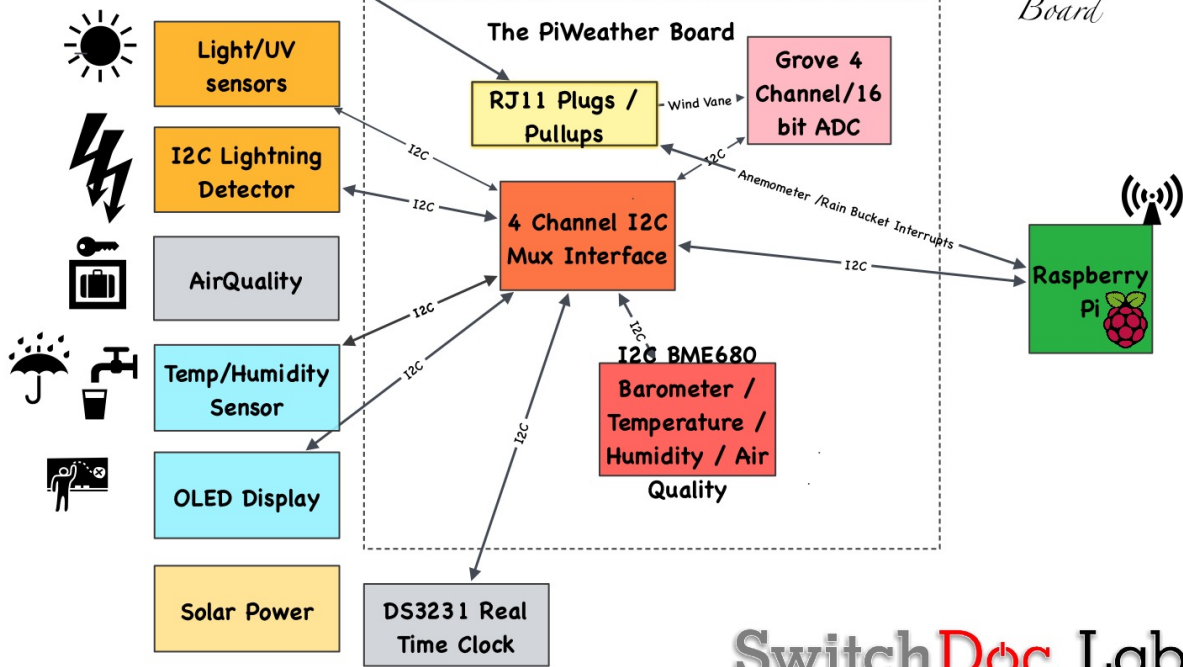

SwitchDoc Labs

Theory of Operation

Software

Software and drivers for the PiWeather board for the Raspberry Pi and the Arduino can be located on the SwitchDoc Labs PiWeather Board product page (shop.switchdoc.com).

RJ11 Plugs / Pullups

The RJ11 Plugs on the PiWeather Board are designed to hook into inexpensive Anemometers, Wind Vanes and Rain Buckets. These plugs are wired to directly support the plugs coming from:

- SwitchDoc Labs WeatherRack (<http://www.switchdoc.com/weatherrack-weather-sensors/>). Available on the SwitchDoc Store and on Amazon.
- ArgentData (<http://www.argentdata.com>)
- SparkFun (<http://www.sparkfun.com>)

TCA9545A I2C Mux

For more information, see the full TCA9545A Specification at: <http://www.ti.com/lit/ds/symlink/tca9545a.pdf>

The TCA9545A is a quad bidirectional translating switch controlled via the I2C bus. The SCL/SDA upstream pair fans out to four downstream pairs, or channels. Any individual SCn/SDn channel or combination of channels can be selected, determined by the contents of the programmable control register. Four interrupt

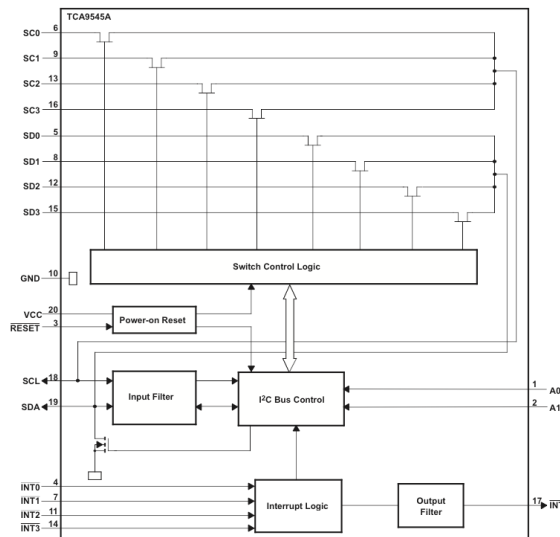

SwitchDoc Labs

inputs (INT3'–INT0'), one for each of the downstream pairs, are provided. One interrupt (INT') output acts as an AND of the four interrupt inputs.

An active-low reset (RESET') input allows the TCA9545A to recover from a situation in which one of the downstream I2C buses is stuck in a low state. Pulling RESET low resets the I2C state machine and causes all the channels to be deselected, as does the internal power-on reset function.

The pass gates of the switches are constructed such that the VCC terminal can be used to limit the maximum high voltage, which will be passed by the TCA9545A. This allows the use of different bus voltages on each pair, so that 1.8-V, 2.5-V, or 3.3-V parts can communicate with 5-V parts, without any additional protection. External pull-up resistors (to the IC, they are already present on the I2CMux Grove Board) pull the bus up to the desired voltage level for each channel. All I/O terminals are 5.5 V tolerant.

Software for the TCA9545 4 Channel Mux follows. Example software is included with each driver.

For the Raspberry Pi: https://github.com/switchdoclabs/SDL_Pi_TCA9545

For the Arduino: https://github.com/switchdoclabs/SDL_Arduino_TCA9545A

I2C Interface

The I2C interface has two parts. There is the incoming I2C Interface from the computer (J4) and then four Grove I2C connectors, one for each of the 4 I2C Mux channels.

ADS1015 4 Channel 12 bit ADC

The ADS1015 device is precision, low-power, 12-bit, I2C-compatible, analog-to-digital converters (ADCs). The ADS1015 devices incorporate a low-drift voltage reference and an oscillator. The ADS1015 also incorporates a programmable gain amplifier (PGA) and a digital comparator. These features, along with a wide operating supply range, make the ADS1015 well suited for power- and space-constrained, sensor measurement applications.

The ADS1015 performs conversions at data rates up to 3300 samples per second (SPS). The device offers input ranges from ± 256 mV to ± 6.144 V, allowing precise large- and small-signal measurements. The

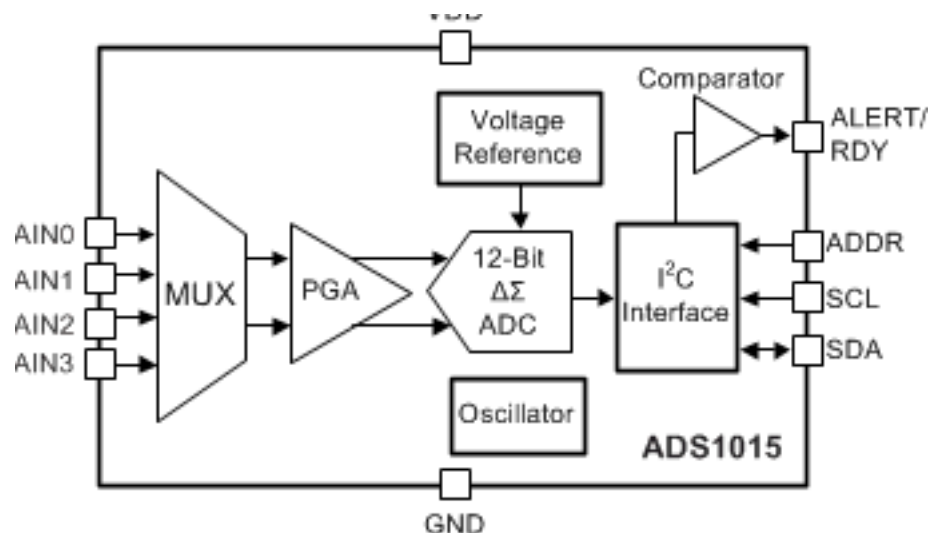

SwitchDoc Labs

ADS1015 features an input multiplexer (MUX) that allows two differential or four single-ended input measurements. Use the digital comparator in the ADS1015 for under- and overvoltage detection. The ADS1015 operate in either continuous-conversion mode or single-shot mode. The devices are automatically powered down after one conversion in single-shot mode; therefore, power consumption is significantly reduced during idle

BME680 Barometer / Temperature / Humidity / Indoor Air Quality

The BME680 is a digital 4-in-1 sensor with gas, humidity, pressure and temperature measurement based on proven sensing principles.

The gas sensor within the BME680 can detect a broad range of gases to measure indoor air quality for personal well being. Gases that can be detected by the BME680 include: Volatile Organic Compounds (VOC) from paints (such as formaldehyde), lacquers, paint strippers, cleaning supplies, furnishings, office equipment, glues, adhesives and alcohol.

The humidity sensor features a best-in-class response time supporting performance requirements for emerging applications such as context awareness, and high accuracy over a wide temperature range.

The pressure sensor is an absolute barometric pressure sensor featuring exceptionally high accuracy and resolution at very low noise.

The integrated temperature sensor has been optimized for very low noise and high resolution. It is primarily used for temperature compensation of the gas, pressure and humidity sensors, and can also be used for estimating ambient temperature.

The BME680 supports a full suite of operating modes which provides huge flexibility in optimizing the device for power consumption, resolution and filter performance.

The specifications for this device are on the SwitchDoc Labs PiWeather Board product page.

PiWeather Board Sensor Compatibility

The anemometer and rain bucket pins are pulled to VDD (3.3V or 5V) via a 10K Ohm pullup resistor. These are intended to connect to interrupt inputs on the host computer. Note: You need to change a constant in the WeatherRack software drivers according to the VDD voltage, or you will not get the correct wind direction.

From SDL_Pi_WeatherRack on github.com/switchdoclabs:

```
# For 5V, use 1.0. For 3.3V use 0.66
```

```
ADJUST30R5 = 0.66
```

```
PowerVoltage = 3.3
```

The standard Anemometer in these devices measures wind speed by closing a contact as a magnet moves past a switch. One contact closure a second indicates 1.492 MPH (2.4 km/h). If you use a different anemometer, this constant can be changed in software.

The tipping bucket Rain Gauge used in the SwitchDoc Labs WeatherRack, the SparkFun Weather Sensor and the ArgentData Sensors. The standard rain gauge used in these devices makes one momentary contact closure that can be recorded with a micro controller interrupt input. Each contact closure of the standard unit indicates 0.011 inch (0.2794 mm). If you use a different tipping rain gauge you can adjust these values in software.

The Wind vane has 8 switches, each connected to a different resistor. The PiWeather Board measures the resistance value of the resistor by measuring the voltage on a resistor divider (with 10K Ohm onboard resistor). With an Arduino, it is measured either with the optional ADS1015 or the internal A/D converters. In the case of a Raspberry Pi measuring this voltage requires an external A/D converter such as the optional ADS1015. See the SwitchDoc Labs WeatherRack Product Specification for more information on the Wind Vane.

See the SwitchDoc Labs drivers provided on www.switchdoc.com.

Note that most RJ11 cables only have 4 wires instead of the six allowed by the plug.

The specifications for this device is on the SwitchDoc Labs PiWeather Board product page.

Default I2C Addresses

The default I2C addresses for the on board devices and the optional devices are shown below.

DEVICE	DESCRIPTION	HEX ADDRESS	COMMENTS
BME680	Barometer Humidity/ Air Quality / Temperature	0x77	Included
ADS1015	ADC	0x48	4 Channel 12 Bit ADC. Can change I2C Addresses.

Operating Values

	Min	Normal	Max	Unit
VDD	3.313V		5.25	V
Idd*		5		mA

*PiWeather Board Power Consumption depends on what other devices you have added to the board.

SwitchDoc Labs

PiWeather Board Board Jumper Pin and Plug Locations

Physical dimensions of board: 65mm x 70mm x 14.5mm(max). Mounting holes inset 3.8mm x 3.8mm from each corner to center of hole. Diameter of hole 2mm.

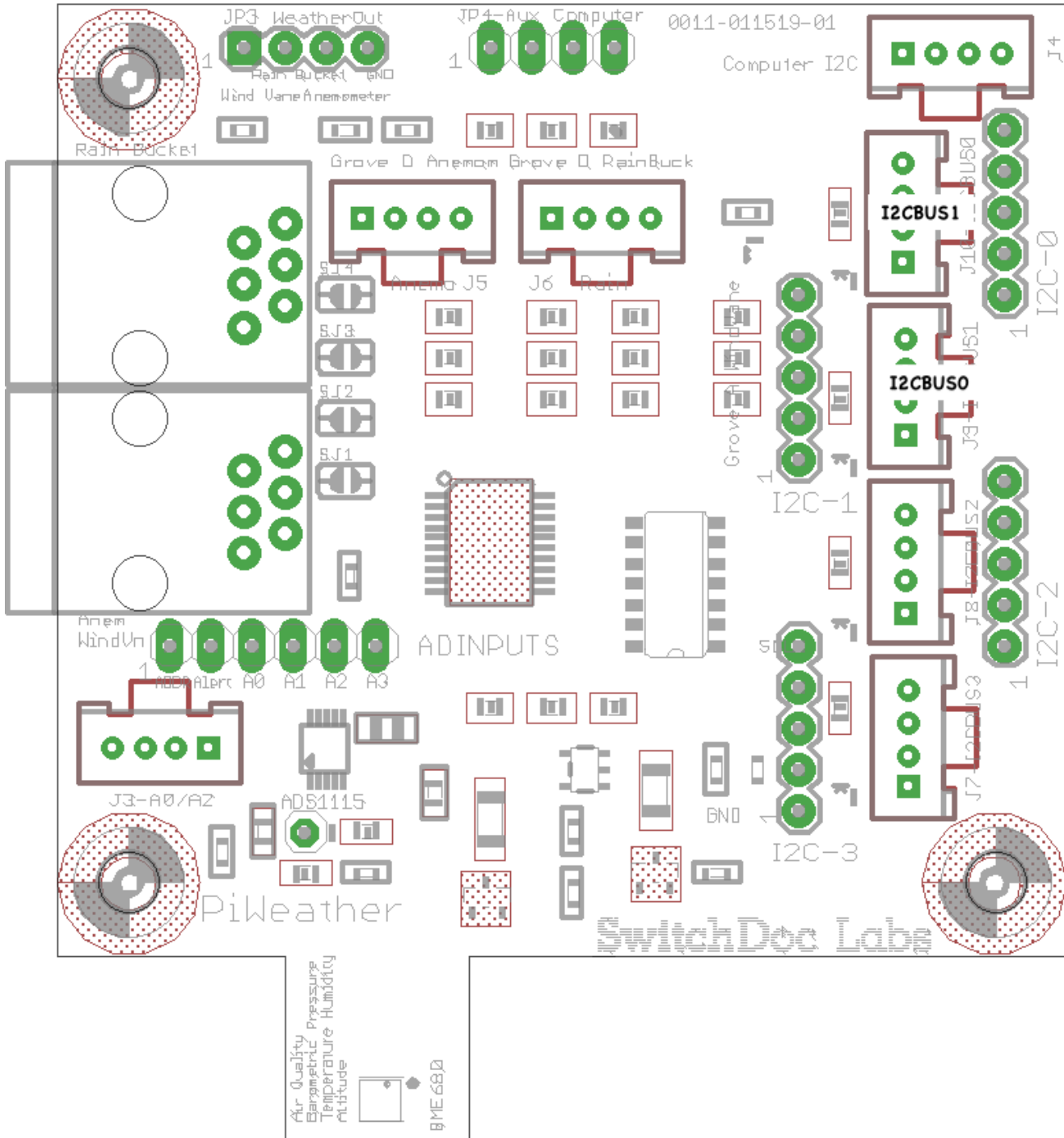

I/O Key:

- I - Digital Input
- O - Digital Output
- A - Analog

Grove Connections

J3 - Grove Analog In

This connector is connected to A0/A2 inputs on the ADS1015 Analog to Digital Converter

J3 - Grove I2C		
Pin 1	A0	A0 Input on ADS1015
Pin 2	A2	A2 Input on ADS1015
Pin 3	VDD	Power for Grove Module
Pin 4	GND	Ground

J4 - Grove Computer I2C - goes to I2C Master (Computer)

This Connector can be used to connect up to an I2C connection on a processor such as the Raspberry PI.

J4 - Grove I2C		
Pin 1	SCL	I2C Clock
Pin 2	SDA	I2C Data
Pin 3	VDD	Power for Grove Module
Pin 4	GND	Ground

J5 - Grove Digital Anemometer

J5 - Grove Digital Anemometer		
Pin 1	D0	Anemometer Output (has 10K Ohm pullup to VDD)
Pin 2	N/C	N/C
Pin 3	N/C	N/C
Pin 4	GND	Ground

J6 - Grove Digital RainBucket

J6 - Grove Digital Rain Bucket		
Pin 1	D0	Rain Bucket Output (has 10K Ohm pullup to VDD)
Pin 2	N/C	N/C
Pin 3	N/C	N/C
Pin 4	GND	Ground

J7 - Grove I2C Connector Bus 3

This is connected to Bus3 on the I2C Mux

J4 - Grove I2C		
Pin 1	SCL	I2C Clock
Pin 2	SDA	I2C Data
Pin 3	VDD	Power for Grove Module
Pin 4	GND	Ground

I2C 4 Channel I2C Mux Grove Connections

Software for the TCA9545 4 Channel Mux follows. Example software is included with each driver.

For the Raspberry Pi: https://github.com/switchdoclabs/SDL_Pi_TCA9545

For the Arduino: https://github.com/switchdoclabs/SDL_Arduino_TCA9545A

J7 - Grove I2C Connector Bus 3

This is connected to Bus3 on the I2C Mux

J7 - Grove I2C		
Pin 1	SCL	I2C Clock
Pin 2	SDA	I2C Data
Pin 3	VDD	Power for Grove Module
Pin 4	GND	Ground

J8 - Grove I2C Connector Bus 2

This is connected to Bus3 on the I2C Mux

J8 - Grove I2C		
Pin 1	SCL	I2C Clock
Pin 2	SDA	I2C Data
Pin 3	VDD	Power for Grove Module
Pin 4	GND	Ground

J9 - Grove I2C Connector Bus 0

Note: On PiWeather boards 0011-101519-01 and before this is mis-marked at being connected to Bus1.

This is connected to Bus0 on the I2C Mux

J9 - Grove I2C		
Pin 1	SCL	I2C Clock
Pin 2	SDA	I2C Data
Pin 3	VDD	Power for Grove Module
Pin 4	GND	Ground

J10 - Grove I2C Connector Bus 1

Note: On PiWeather boards 0011-101519-01 and before this is mis-marked at being connected to Bus0.

This is connected to Bus1 on the I2C Mux

J9 - Grove I2C		
Pin 1	SCL	I2C Clock
Pin 2	SDA	I2C Data
Pin 3	VDD	Power for Grove Module
Pin 4	GND	Ground

Plug Functions

J1 - Anemometer / Wind Vane RJ11 Plug

Used to connect the PiWeather Board to a wind vane and anemometer such as used in the SwitchDoc Labs WeatherRack, the SparkFun Weather Sensor and the ArgentData Sensors. The standard Anemometer in these devices measures wind speed by closing a contact as a magnet moves past a switch. One contact closure a second indicates 1.492 MPH (2.4 km/h). If you use a different anemometer, this constant can be changed in software. The Wind vane has 8 switches, each connected to a different resistor. The PiWeather Board measures the resistance value of the resistor by measuring the voltage on a resistor divider (with 10 K Ohm resistor). With an Arduino, it is measured either with the optional ADS1015, SwitchDoc Labs Grove 16 Bit ADC or the internal 10 bit A/D converters. In the case of a Raspberry Pi measuring this voltage requires an external A/D converter such as the SwitchDoc Labs Grove 16 Bit ADC. See the SwitchDoc Labs WeatherRack Product Specification for more information on the Wind Vane.

NAME	PIN	I/O	DESCRIPTION
N/C	J2 / 1		No Connection
GND	J3 / 2	A	Connected to GND
GND	J3 / 3	A	Connected to GND
Anemometer	J4 / 4	A	Connected to Anemometer pin on JP2 and 10K Ohm Pullup to VDD
Wind Vane	J5 / 5	A	Connected to Wind Vane Pin on JP2 and also to ADC-A1 on JP5 and JP8 for use by the optional ADS1015 ADC or SwitchDoc Labs ADS1116 and 10K Ohm Pullup to VDD
N/C	J6 / 6		No Connection

J2 - Rain Bucket RJ11 Plug

Used to connect the PiWeather Board to a tipping bucket Rain Gauge used in the SwitchDoc Labs WeatherRack, the SparkFun Weather Sensor and the ArgentData Sensors. The standard rain gauge used in these devices makes one momentary contact closure that can be recorded with a micro controller interrupt input. Each contact closure of the standard unit indicates 0.011 inch (0.2794 mm). If you use a different tipping rain gauge you can adjust these values in software.

Note that most RJ11 cables only have 4 wires instead of the six allowed by the plug.

NAME	PIN	I/O	DESCRIPTION
N/C	J1 / 1		No Connection
N/C	J1 / 2		No Connection

SwitchDoc Labs

GND	J1 / 3	A	Connected to GND
RainBucket Contact	J1 / 4	A	Connected to Rain Gauge ping on JP2 and 10K Ohm Pullup to VDD
N/C	J1 / 5		No Connection
N/C	J1 / 6		No Connection

Jumper Pin Functions

JP1 - Optional A/D Inputs for Optional ADS1015 ADC

NOTE: This header does not have the JP1 label on the board. JP1 is located directly below the Anem Wind Vane RJ11 plug and above J3. It is marked ADINPUTS.

Connect up external A/D Inputs using this header. The ADS1015 chips have a base 7-bit I2C address of 0x48 and an addressing scheme that allows four different addresses using just one address pin. To program the address, connect the address pin as follows:

- 0x48 (1001000) ADDR -> GND
- 0x49 (1001001) ADDR -> VDD
- 0x4A (1001010) ADDR -> SDA
- 0x4B (1001011) ADDR -> SCL

The ADDR should be connected to GND for the default address 0x48. **Do not leave it floating.**

NAME	PIN	I/O	DESCRIPTION
ADDR	JP8 / 1	I	I2C slave address select
ALRT	JP8 / 2	O	Digital comparator output or conversion ready
A0	JP8 / 3	A	Differential channel 1: Positive Input or single-ended channel 1 input
A1	JP8 / 4	A	Differential channel 1: Negative Input or single-ended channel 2 input. Connected to WindVane Input on JP1
A2	JP8 / 5	A	Differential channel 2: Positive Input or single-ended channel 3 input.
A3	JP8 / 6	A	Differential channel 2: Negative Input or single-ended channel 4 input

JP2 - BME680 Address Select

The 7-bit device address is 111011x. The 6 MSB bits are fixed. The last bit is changeable by JP2 value and can be changed during operation. Connecting SDO to GND results in slave address 1110110 (0x76);

SwitchDoc Labs

connection it to VDDIO results in slave address 1110111 (0x77), which is the same as BMP280's I2C address. The JP2 pin cannot be left floating; if left floating, the I2C address will be undefined.

NAME	PIN	I/O	DESCRIPTION
BME680 Address Select	JP1 / 1	I	Tied through 10K Pullup to VDD (0x77) connect to GND for (0x76)

JP3 - Weather Out

This is the PiWeather Board header that can be optionally used instead of the Grove Connectors

NAME	PIN	I/O	DESCRIPTION
WindVane	JP2 / 1	O	Analog value from WindVane
RainBucket	JP2 / 2	I	Active Low Interrupt on each click of the Rain Bucket - Not Debounced. 10K pullup resistor
Anemometer	JP2 / 3	I	Active Low Interrupt on each click of the Anemometer - Not Debounced. 10K pullup resistor
GND	JP2 / 4	A	Connected to GND

JP4 - Computer AUX for TCA9545A

This is an I2C Pin Header for optional non-Grove connectors. Connected directly to the I2C Grove Connectors.

NAME	PIN	I/O	DESCRIPTION
RESETN	JP4 / 1	I	Open Drain Reset line for TCA9545A 10K Ohm Pullup to VDD
INTN	JP4 / 2	O	Open Drain Interrupt Line from TCA9545A
A0	JP4 / 3	I	TC9545A I2c A0 Address - 10K Ohm Pulled up to VDD
A1	JP4 / 4	I	TC9545A I2c A1 Address - 10K Ohm Pulled up to VDD

Note: These are marked incorrectly on the silkscreen. Pin numbers are reversed.

I2C-0 - Multiplexed I2C Bus 0

Multiplexed I2C Bus 0.

NAME	PIN	I/O	DESCRIPTION
INT0'	JP2 / 1	I	Open Drain Input for I2C Bus 0 Input. Tied to VDU0 with 10K Pullup
GND	JP2 / 2	A	GND
VDU0	JP2 / 3	A	Power Supply for I2C Bus 0. Tie to 3.3V or 5.0V.
SD0	JP2 / 4	I/O	Serial bus data line. open-drain input/output. Tied to VDU0 with 10K Pullup
SC0	JP2 / 5	O	Serial bus clock line; open-drain output. Tied to VDU0 with 10K Pullup

I2C-1 - Multiplexed I2C Bus 1

Multiplexed I2C Bus 1.

NAME	PIN	I/O	DESCRIPTION
INT1'	JP3 / 1	I	Open Drain Input for I2C Bus 1 Input. Tied to VDU1 with 10K Pullup
GND	JP3 / 2	A	GND
VDU1	JP3 / 3	A	Power Supply for I2C Bus 1. Tie to 3.3V or 5.0V.
SD1	JP3 / 4	I/O	Serial bus data line. open-drain input/output. Tied to VDU1 with 10K Pullup
SC1	JP3 / 5	O	Serial bus clock line; open-drain output. Tied to VDU1 with 10K Pullup

I2C-2 — Multiplexed I2C Bus 2

Multiplexed I2C Bus 2.

NAME	PIN	I/O	DESCRIPTION
INT2'	JP5 / 1	I	Open Drain Input for I2C Bus 2 Input. Tied to VDU2 with 10K Pullup
GND	JP5 / 2	A	GND
VDU2	JP5 / 3	A	Power Supply for I2C Bus 2. Tie to 3.3V or 5.0V.

SwitchDoc Labs

SD2	JP5 / 4	I/O	Serial bus data line. open-drain input/output. Tied to VDU2 with 10K Pullup
SC2	JP5 / 5	O	Serial bus clock line; open-drain output. Tied to VDU2 with 10K Pullup

I2C-3 - Multiplexed I2C Bus 3

Multiplexed I2C Bus 3.

NAME	PIN	I/O	DESCRIPTION
INT3'	JP4 / 1	I	Open Drain Input for I2C Bus 3 Input. Tied to VDU3 with 10K Pullup
GND	JP4 / 2	A	GND
VDU3	JP4 / 3	A	Power Supply for I2C Bus 3. Tie to 3.3V or 5.0V.
SD3	JP4 / 4	I/O	Serial bus data line. open-drain input/output. Tied to VDU3 with 10K Pullup
SC3	JP4 / 5	O	Serial bus clock line; open-drain output. Tied to VDU3 with 10K Pullup

What is a Grove Connector?

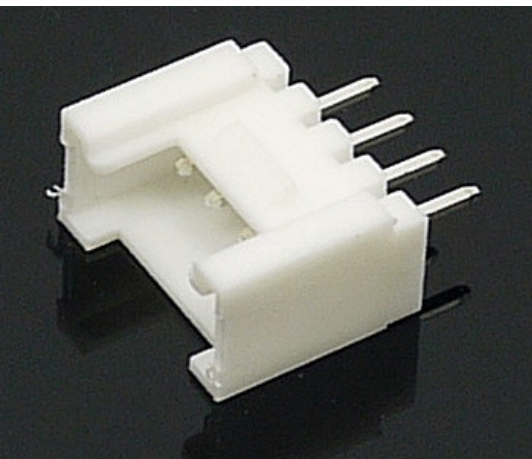

The way we have been wiring I2C connections before just didn't work for large projects. Basically, we used to put the I2C bus to screw terminals or snap down connectors and then ran wires to each device. This would not work for complex projects. Because of this, we moved to Grove connectors.

There are dozens of Grove I2C sensors out now. Many different kinds of cables and I2C Hubs.

We quickly found the connectors and their respective cables very useful. With the large selection of Grove I2C devices available, we decided to include a Grove connector on all our future I2C boards. The white connectors on the PiWeather Board board picture at the top are Grove connectors for easy, non-soldered connections to the I2C bus and for data inputs. The picture below shows the SunRover robot built using Grove connectors for the 8 different I2C busses in the robot. A Grove OLED

display is shown underneath the picture.

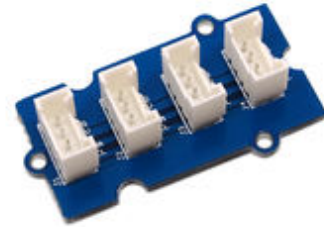
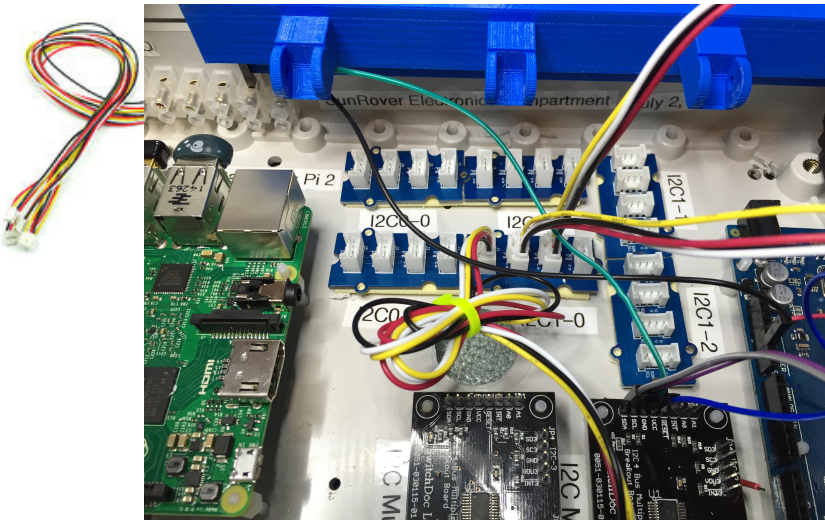

Connecting to Grove Connectors

There are a number of Grove shields and Hats for Raspberry Pi and Arduino devices. Grove I2C Connectors are keyed so they can not be plugged in incorrectly. Below is the I2CMux board hooked up with both Grove and non-Grove devices.

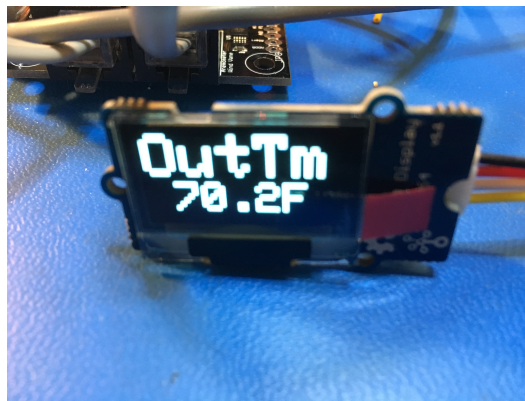

What Grove Connectors Are On The Weather Pi Arduino?

There are two types of Grove Connectors on the PiWeather Board board. There is one Grove I2C and two Grove Digital connectors.

Grove Digital

A digital Grove connector consists of the standard four lines coming into the Grove plug. The two signal lines are generically called D0 and D1. Most modules only use D0, but some do (like the LED Bar Grove display) use both. Often base units will have the first connector called D0 and the second called D1 and they will be wired D0/D1 and then D1/D2, etc.

Grove Digital		
Pin 1	D0	Primary Digital Input/Output
Pin 2	D1	Secondary Digital Input/Output
Pin 3	VCC	Power for Grove Module (5V or 3.3V)
Pin 4	GND	Ground

Grove I2C

SwitchDoc Labs customers know that our favorite devices are I2C sensors. There are many types of I2C Grove sensors available. Most are 5V/3.3V devices, but there are a few that are only 3.3V or 5.0V. You need to check the specifications.

The Grove I2C connector has the standard layout. Pin 1 is the SCL signal and Pin 2 is the SDA signal. Power and Ground are the same as the other connectors. This is another special version of the Grove Digital Connector. In fact, often the I2C bus on a controller (like the ESP8266, Raspberry Pi and the Arduino) just uses Digital I/O pins to implement the I2C bus. The pins on the Raspberry Pi and Arduino are special with hardware support for the I2C bus. The ESP8266 is purely software.

Note that the Grove I2C Connectors on the PiWeather Board is a 5V or 3.3V (depending on what VDD is connected to) I2C connector.

Grove I2C		
Pin 1	SCL	I2C Clock
Pin 2	SDA	I2C Data
Pin 3	VCC	Power for Grove Module (5V or 3.3V)
Pin 4	GND	Ground