



The **SunAirPlus2 Solar Power Controller Board** for Raspberry Pi, Arduino and Cell Phone Charger is a 3rd Generation Solar Charging and Sun Tracking Board designed by and manufactured by SwitchDoc Labs.

You can use this board to power your projects and add a servo or stepper motor to allow it to track the sun to generate even more power. It incorporates a number of outstanding features in a very compact, inexpensive single fully assembled and tested PC Board. SunAirPlus2 is customizable with your software and hardware.

#### Features and Benefits:

- Uses 6V Solar Cells
- Use 3.7V LiPo Cells for batteries
- Has LiPo to 5V voltage boost built in
- Directly powers Raspberry Pi / Arduino
- Works Raspberry Pi (3.3V) GPIO and Arduino (5.0V) GPIO
- Built-in INA3221 - 3 channel current/voltage measurement
- Built-in Interface for Servo motor or Stepper motor
- Charges iPhones and other phones or devices
- Approximates an MPPT (Maximum Power Point Tracking) charging system
- Comes with Driver Software to read Solar Data
- Low Power
- Low Cost
- Full Test Code Supplied
- Quantity Discounts Available
- Immediate Availability

## Introduction

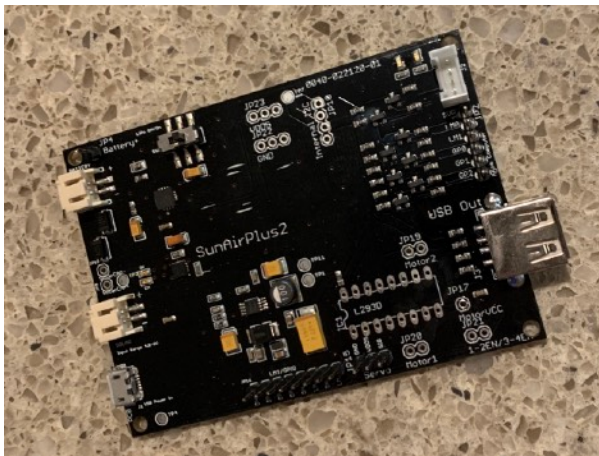



SunAirPlus2 is a solar power controller / sun tracker / power supply system developed by SwitchDoc Labs to power Arduino and Raspberry Pi based systems. The board has solar panel charge control system, a voltage booster, an A/D system and GPIO interface circuitry systems for voltage level shifting and for servo motors as well as aiding in stepper motor control. SunAirPlus2 contains INA3221 voltage and current sensing circuitry and an optional stepper motor controller built into the SunAirPlus2 board.

Additional code and examples on [shop.switchdoc.com](http://shop.switchdoc.com) on the SunAirPlus2 Product Page

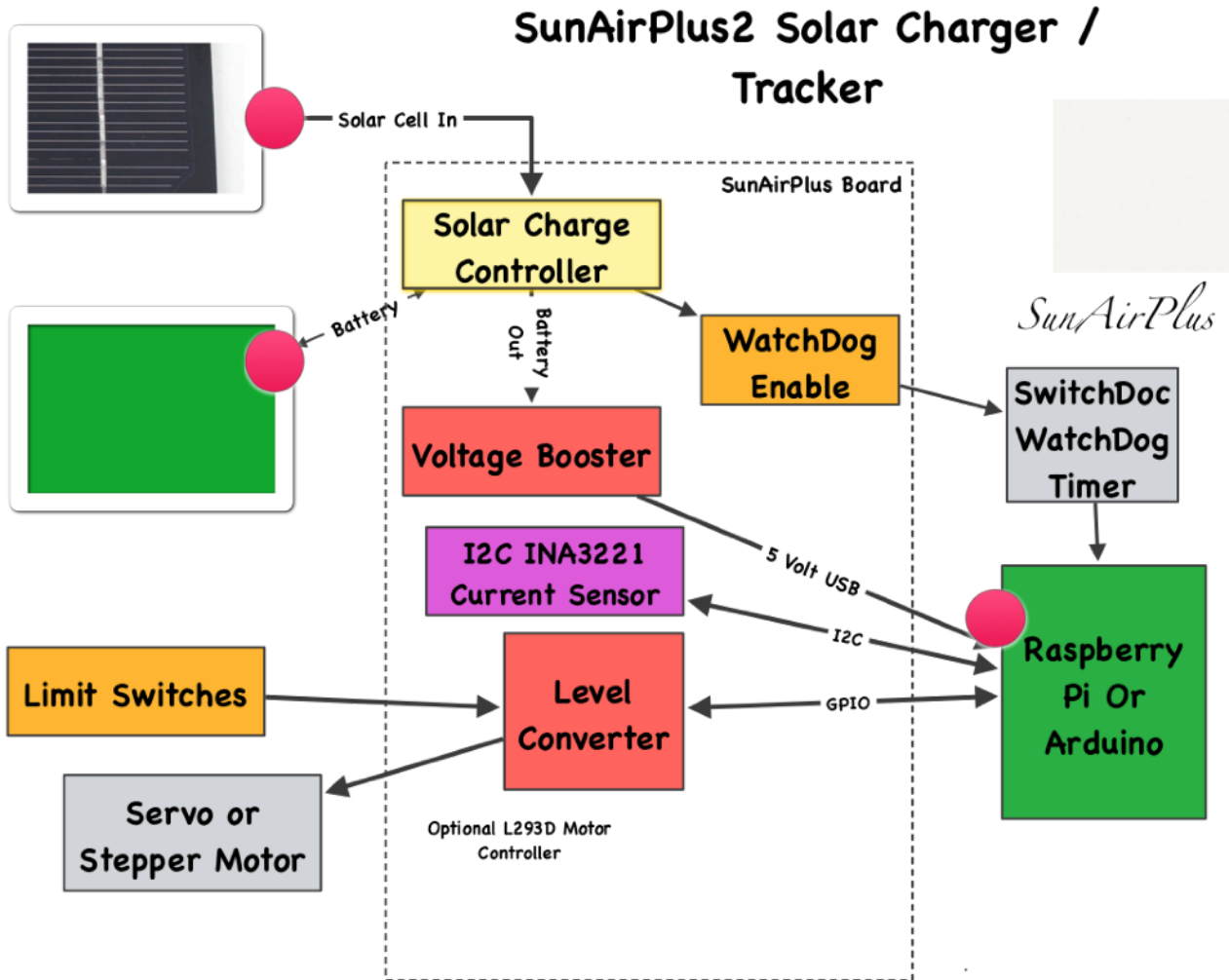
### Block Diagram



 = Accurate Power /Voltage / Current Measurements

 = Accurate Analog Measurements

### Theory of Operation

---

#### Solar Charge Controller

The Solar Charge Controller on SunAirPlus2 is based around a CN3065 Lithium Ion Charge Controller to run the charging sequence for the batteries. The chip does an approximation of the MPPT (Maximum Power Transfer Tracking).

It is the purpose of the MPPT system to sample the output of the cells and apply the proper resistance (load) to obtain maximum power for any given battery and temperature conditions. Although the fully charged battery pack voltage may be close to the solar cell maximum power point voltage, this is unlikely to be true at sunrise when the battery has been partially discharged. Charging may begin at a voltage considerably below the solar panel maximum power point voltage.

When the batteries are fully charged and the solar power production exceeds the load of the computer, the CN3065 can no longer operate the panel at its maximum power point as the excess power has no load to absorb it. The CN3065 must then shift the solar power operating point away from the peak power point until production exactly matches demand.

The CN3065 is set in SunAirPlus2 to deliver a maximum of 1000ma instantaneously to the connected LiPo batteries. Now note, that doesn't mean you can't use more than 6W of solar panels. The 6W solar panels won't be delivering 1000ma most of the time.

---

#### Voltage Booster

In order to boost the nominal 3.7V - 4.2V output from the LiPo batteries up to 5V, SunAirPlus2 uses a voltage booster. It uses an ISL97156 PWM Step-Up Regulator to do the step up in voltage. This design uses an PWM (Pulse Width Modulated) oscillator run through an inductor with a feedback loop to increase the voltage up to a regulated 5V. Note that this voltage will start to come down below 5V when you overload the board (exceed 1000ma) or the LiPo batteries get below about 3.6V. A good system will monitor this voltage and cut the power to the computers when things get low. If you are charging your phone, it doesn't matter.

---

#### Level Converters

Outputs and inputs from the Raspberry Pi are 3.3V. You can't drive them with 5V lines without potentially destroying the Pi. Why is this? The Raspberry PI has protection diodes between the pin and 3.3V and ground. Positive voltages greater than 3V3 + one "diode drop" (normally 0.5V) will be shorted to 5V, this means that if you put a 5V power supply on the GPIO pin you will "feed" the 3V3 supply with 4.5 Volt (5V - the diode drop of 0.5V) and that may damage 3V3 logic.

A designer should only use 3.3V outputs connected to your Raspberry Pi GPIO pins without putting a voltage level converter between the devices. Note: You can DRIVE most 5V device inputs with the Raspberry Pi 3.3V GPIO outputs. Most devices will read 3.3V inputs as a logic one. In SunAirPlus2 there are bidirectional level converters. Figure 4 shows a simple bi-directional logic level FET based converter. You can set VDD to either 3.3V or 5.0V and SunAirPlus2 will adjust the levels..

---

## Current/Voltage Sensors - INA3221

This is one of the most interesting parts of the SunAirPlus2 board. It allows you to get dynamic and accurate information on how your Solar Power system is running.

The INA3221 is a three-channel, high-side current and bus voltage monitor with an I2C interface. The INA3221 monitors both shunt voltage drops and bus supply voltages in addition to having programmable conversion times and averaging modes for these signals. There are three 0.1 Ohm shunts on the board.

Below are some results from the INA3221 test software (note the SunAirPlus2 is on 0x41, not 0x40).

### Test SDL\_Pi\_INA3221 Version 1.0 - SwitchDoc Labs

Sample uses 0x40 and SunAirPlus2 board INA3221

Will work with the INA3221 SwitchDoc Labs Breakout Board

```
-----  
LIPO_Battery Bus Voltage: 4.15 V  
LIPO_Battery Shunt Voltage: -9.12 mV  
LIPO_Battery Load Voltage: 4.14 V  
LIPO_Battery Current 1: 91.20 mA  
  
Solar Cell Bus Voltage 2: 5.19 V  
Solar Cell Shunt Voltage 2: -73.52 mV  
Solar Cell Load Voltage 2: 5.12 V  
Solar Cell Current 2: 735.20 mA  
  
Output Bus Voltage 3: 4.88 V  
Output Shunt Voltage 3: 48.68 mV  
Output Load Voltage 3: 4.93 V  
Output Current 3: 486.80 mA
```

Software for the INA3221 is available from SwitchDoc Labs on <http://github.com/switchdoclabs>.

The default I2C address is 0x41. If you have more than one SunAirPlus2 in your system, consider using a SwitchDoc Labs I2C 4 channel Mux to avoid address conflicts.

---

### Servo Motor Interface

Hobby servomotors are an inexpensive method of motion control. They provide an off-the-shelf solution for most hobbyist's needs. Servomotors allow quite accurate positioning of motors via PWM (Pulse Width Modulation) control which harkens back 30 years or more all the way to pure analog systems.

To interface a servo motor to SunAir is simple. You connect a servo to JP15 on the SunAir board. GND, VDD5 (the SunAir Power Supply) and SIG. SIG is connected to a GPIO pin on the Arduino or Raspberry Pi and provides the control signal to the servo motor. To see how to control a servo motor with your Raspberry Pi, check out the tutorial on Hertaville - <http://hertaville.com/2014/07/15/rpiservo/>.

---

### Stepper Motor Interface

Interfacing a stepper motor to SunAirPlus2 is a little more complicated. SunAirPlus2 contains a space for a stepper motor driver utilizing the L293D Dual H-Bridge Motor Driver. There is an excellent tutorial on Instructables: <http://www.instructables.com/id/Control-your-motors-with-L293D-and-Arduino/>. The L293D can be used for servomotors, stepper motors or DC motors.

JP20, JP19, JP17, JP21 and IC1 are all involved with the control and powering of the stepper motor. See the sections below on each of the connectors.

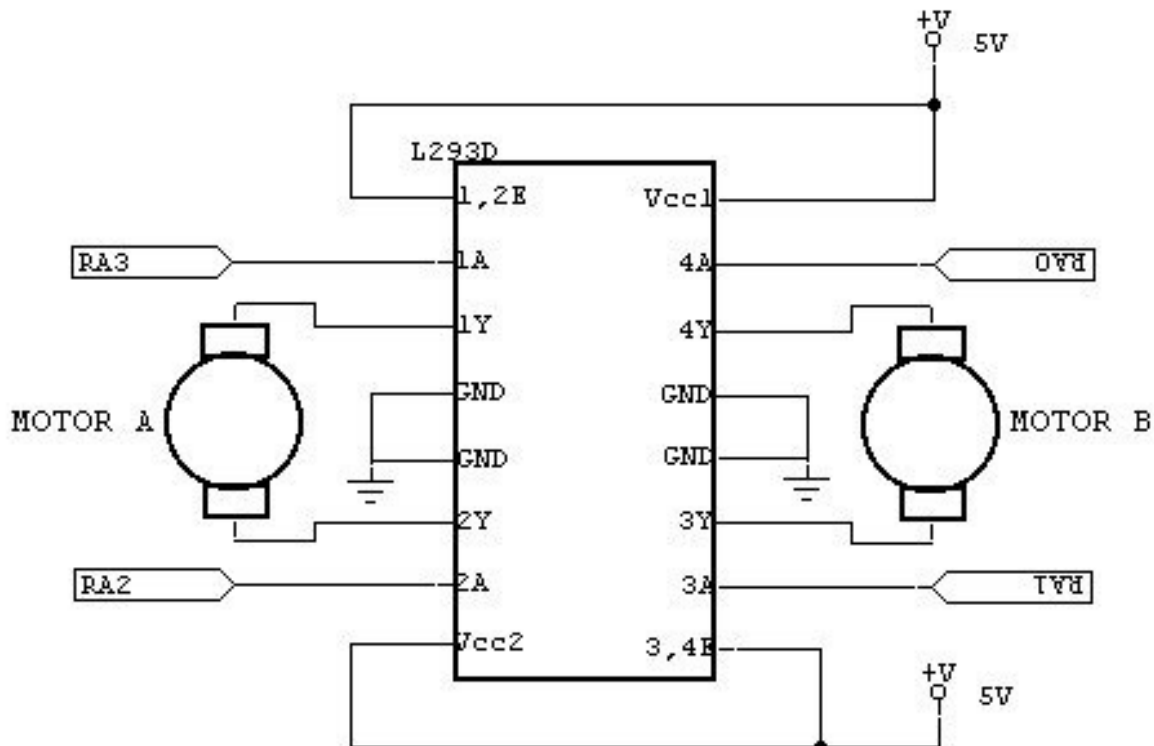
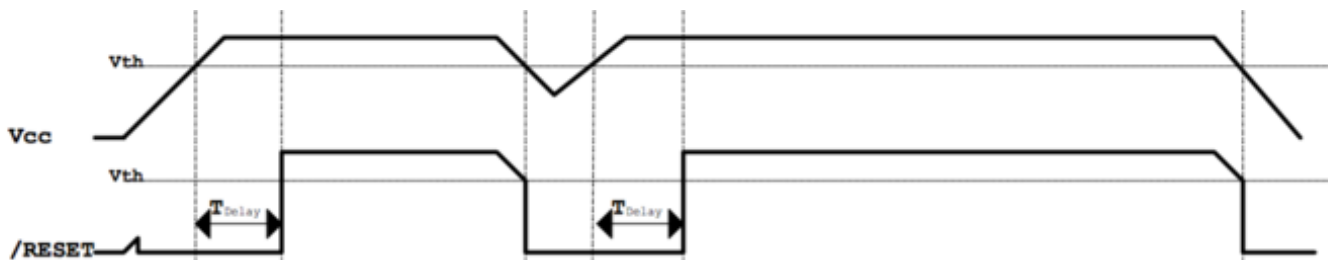

Figure 6: Block Diagram of L293D Connected to a Stepper Motor

### Other Modules

#### WatchDog Timer Enable

You can make your project more reliable by using an external WatchDog Timer (see the tutorial series on [SwitchDoc.com - Reliable Projects: WatchDog Timers for Raspberry Pi and Arduinos](http://www.switchdoc.com/2014/11/reliable-projects-watchdog-timers-raspberry-pi-arduinos/) - <http://www.switchdoc.com/2014/11/reliable-projects-watchdog-timers-raspberry-pi-arduinos/>) The tutorial series shows how you use one to make your small computer system more reliable. This piece of circuitry on SunAirPlus2 will disable the WatchDog Timer if the supply voltage is too low (less than 4.65V in this case). This keeps the WatchDog Timer from trying to start the computer up when there isn't enough power to run the computer properly.



### Operating Values

	Min	Normal	Max	Unit
Vin Solar	4.8	5.0	6.5 (10 seconds)	V
Icharge	800	1000	1200	mA
Iload	0		1000	mA
Vbattery		4.3		V
Vsource USB		5.0		V
Vdestination USB (VDD5)	4.75	5.0	5.25	V

### SunAirPlus2 Board Jumper Pin and Plug Locations

Physical dimensions of board: 63.5mm x 89mm x 12mm(max). Mounting holes inset 2.0mm x2.0mm from each corner to center of hole. Diameter of hole 2mm.

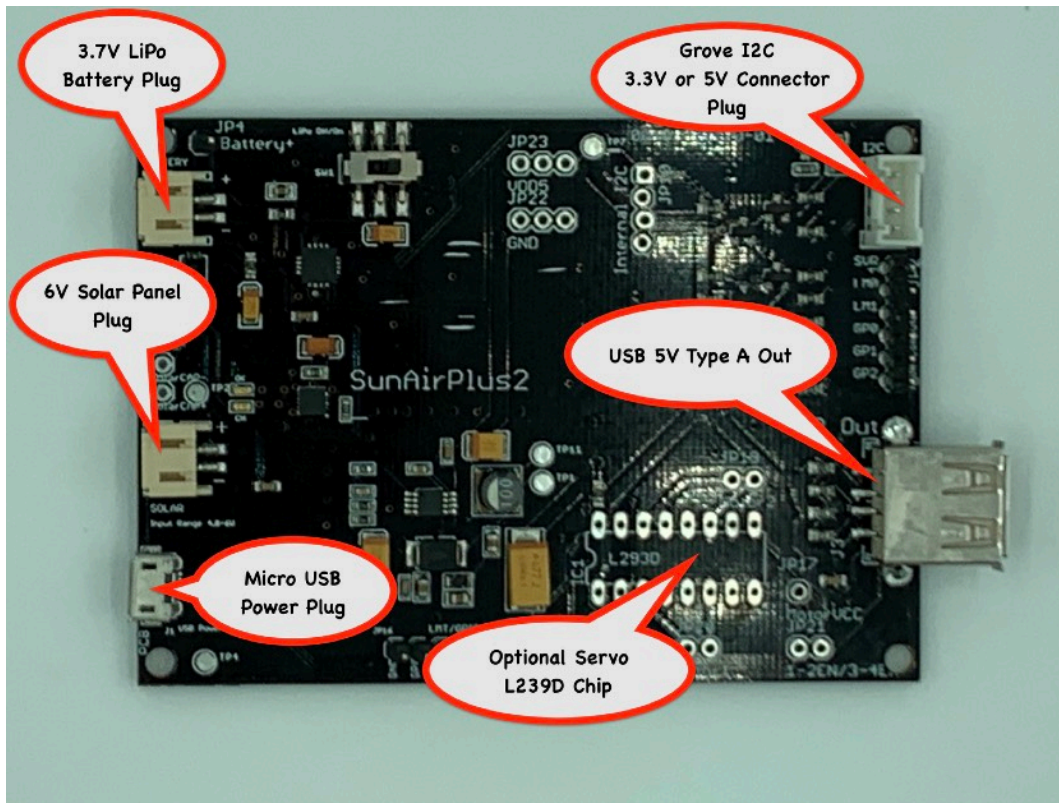

## I/O Key:

I - Digital Input  
O - Digital Output  
A - Analog

**LED Indicators**

NAME	PIN	I/O	DESCRIPTION
EXTPOWER	LED1	A	External Power Connected to VDD from Computer
GP0 STATE	LED2	A	Driven by EXTGP0 from Computer. Buffered

**J2 - Grove I2C Connector**

3.3V or 5V compatible

NAME	PIN	I/O	DESCRIPTION
SCL	J2 / 1	I	I2C Clock Line - Open Drain 10KOhm Pullup
SDA	J2 / 2	I/O	I2C Data Line - Open Drain 10KOhm Pullup
VDD	J2 / 3	A	I2C Supply Voltage (3.3V or 5V Compatible)
GND	J2 / 4	A	Ground



## JP22 - Utility Ground

NAME	PIN	I/O	DESCRIPTION
GND	JP22 / 1	A	Utility Connection to GND
GND	JP22 / 2	A	Utility Connection to GND
GND	JP22 / 3	A	Utility Connection to GND

**JP23 - Utility VDD5**

NAME	PIN	I/O	DESCRIPTION
VDD5	JP23 / 1	A	Utility Connection to VDD5
VDD5	JP23 / 2	A	Utility Connection to VDD5
VDD5	JP23 / 2	A	Utility Connection to VDD5

**J4 - LiPo Battery Out**

Direct output from the LiPo Battery. Useful for connecting to boards like SwitchDoc Labs USB PowerControl. The USB PowerControl will keep a USB powered device off until the Battery is about 3.8V to prevent constant reboot cycles when a Solar Powered System is recovering from a brownout event.

NAME	PIN	I/O	DESCRIPTION
LiPo Battery Out	JP4 / 1	A	Direct connection from + terminal on LiPo Battery

**JP9 - Solar Capacitor Plus**

Adding an optional large filter 4700uF capacitor across JP9 and JP10 will help to stabilize the Solar Cell Voltage. Useful for some solar panels.

NAME	PIN	I/O	DESCRIPTION
SolarCAP+	JP9 / 1	A	Connect to + on Optional Filter Capacitor for Solar Cell

**JP18 - Solar Capacitor Minus**

NAME	PIN	I/O	DESCRIPTION
SolarCAP-	JP9 / 2	A	Connect to - on Optional Filter Capacitor for Solar Cell

### JP10 - Spare Internal I2C

You can connect up additional 5V I2C devices to this port.

NAME	PIN	I/O	DESCRIPTION
SCL	JP10 / 1	I	Serial bus clock line; open-drain input. 10K Ohm Pullup to VDD5. Buffered.
SDA	JP10 / 2	I/O	Serial bus data line; open-drain input/output. 10K Ohm Pullup to VDD5. Buffered.
VDD5	JP10 / 3	A	Connected to VDD5 (5V I2C Bus)
GND	JP10 / 4	A	GND

## JP13 - External Computer Connections

This is the main connection port to connect to external computers. Most of these pins are self-explanatory but several merit additional explanations.

- EXTGP0 - Connected to Left Photocell A/D. Can be used as a Normal GP0 I/O line if you don't connect a Left Photocell. It still has a 1uF capacitor connected to GND even without a photocell connected. This will slow down the effective rate that you can switch this pin on and off.
- EXTGP1 - Connected to Right Photocell A/D. Can be used as a Normal GP0 I/O line if you don't connect a Right Photocell. It still has a 1uF capacitor connected to GND even without a photocell connected. This will slow down the effective rate that you can switch this pin on and off.

NAME	PIN	I/O	DESCRIPTION
EXTSERVO	JP13 / 1	I/O	Connected to Servo Signal Output on JP15 - can be used General I/O. 10K Ohm Pullup to VDD. Buffered.
EXTLIMIT0	JP13 / 2	I/O	Connected to LIMIT0 on JP16. 10K Ohm Pullup to VDD. Buffered.
EXTLIMIT1	JP13 / 3	I/O	Connected to LIMIT1 on JP16. 10K Ohm Pullup to VDD. Buffered.
EXTGP0	JP13 / 4	I/O	Connected to GP0 on JP16. 10K Ohm Pullup to VDD. Buffered. Buffered Signal also drives LED2.
EXTGP1	JP13 / 5	I/O	Connected to GP1 on JP16. 10K Ohm Pullup to VDD. Buffered.
EXTGP2	JP13 / 6	I/O	Connected to GP2 on JP16. 10K Ohm Pullup to VDD. Buffered.

## JP15 - Servo Connection

You can drive a 5V Servo from this connection. Drive the EXTSERVO line on JP13 with a PWM line from an Arduino or from a GPIO line on the Raspberry Pi (Using a GPIO library that supports PWM).

NAME	PIN	I/O	DESCRIPTION
GND	JP15 / 1	A	GND
VDD5	JP15 / 2	A	Connected to VDD5
SERVO	JP15 / 3	I/O	Connected EXTSERVO on JP13. Buffered.

## JP16 - Limit Switches / GPIO

These pins are used for general I/O purposes as well as providing an interface for Limit Switches. The Limit Switch pins can also be used for general I/O purposes.

NAME	PIN	I/O	DESCRIPTION
GND	JP16 / 1	A	GND
GP0	JP16 / 2	I/O	Connected to EXTGP0 through level shifting buffer. 10K Ohm Pullup to VDD5
GP1	JP16 / 3	I/O	Connected to EXTGP1 through level shifting buffer. 10K Ohm Pullup to VDD5
GP2	JP16 / 4	I/O	Connected to EXTGP2 through level shifting buffer. 10K Ohm Pullup to VDD5
GND	JP16 / 5	A	GND
LIMIT0	JP16 / 6	I/O	Connected to EXTLIMIT0 through level shifting buffer. 10K Ohm Pullup to VDD5
GND	JP16 / 7	A	GND
LIMIT1	JP16 / 8	I/O	Connected to EXTLIMIT1 through level shifting buffer. 10K Ohm Pullup to VDD5

## Stepper Motor Connections

### JP17 - Motor VCC

Connect to external Motor Power supply (up to 36V per the L293D specification) or to VDD5 if you are driving the stepper motor internally

NAME	PIN	I/O	DESCRIPTION
Stepper Motor VCC	JP17 / 1	A	External Motor VCC - up to 36V for L293D

### JP20 - Motor 1 (Motor A) Connection

Stepper motor coil connections. See diagram and tutorial reference in Theory of Operation section.

NAME	PIN	I/O	DESCRIPTION
1Y	JP20 / 1	A	Output 1
2Y	JP20 / 2	A	Output 2

### JP19 - Motor 2 (Motor B) Connection

Stepper motor coil connections. See diagram and tutorial reference in Theory of Operation section.

NAME	PIN	I/O	DESCRIPTION
4Y	JP19 / 1	A	Output 4
3Y	JP19 / 2	A	Output 3

### JP21 - Motor Enable

Stepper Motor Enable Lines. See diagram and tutorial reference in Theory of Operation section.

NAME	PIN	I/O	DESCRIPTION
1-2EN	JP21 / 1	A	Enable Motor 1 (Motor A) Connect to VDD5 or GPIO Lines
3-4EN	JP22 / 2	A	Enable Motor 2 (Motor B) Connect to VDD5 or GPIO Lines

## On the L293D IC - Motor Coil Control Lines

Stepper Motor Coil Control Lines. See diagram and tutorial reference in Theory of Operation section.

NAME	PIN	I/O	DESCRIPTION
1A	IC1 / 2	A	Connected to buffered SERVO Line (JP13 / 5)
2A	IC1 / 7	A	Connected to buffered GP0 Line (JP13 / 8)
3A	IC1 / 10	A	Connected to buffered GP1 Line (JP13 / 9)
4A	IC1 / 15	A	Connected to buffered GP2 Line (JP13 / 10)

## Plug Functions

### J1 - MicroB USB In - Charge and Programming

Female MicroB USB Plug. Used for charging the LiPo battery. D1, D+ are passed to the USB A Out plug allowing programming of Arduinos from the USB A Out plug. Diode protected for back EMF.

### J3 - USB A Out - Power and Programming

Female USB A Plug. Used for powering the external computer. D1, D+ are passed to the USB A Out plug from the MiniB USB Plug allowing programming of Arduinos from this plug. USB A Out will also charge tables and cell phones.

### J5 - LiPo Battery In

Battery connector is JST 2.0.

NAME	PIN	I/O	DESCRIPTION
+	J5 / 1	A	Connect to + Terminal of 3.7V Lithium Ion polymer battery
GND	J5 / 2	A	Connect to - Terminal of 3.7V Lithium Ion polymer battery

### J6 - Solar Cells In

Solar Panel connector is JST 2.0.

NAME	PIN	I/O	DESCRIPTION
+	J6 / 1	A	Connect to + Terminal of 6V Solar Cell Panel. Diode protected for back EMF.
GND	J6 / 2	A	Connect to - Terminal of 6V Solar Cell Panel

### Switch Functions

#### SW1 - Turn LiPo Battery to Voltage Booster On/Off

Turning this switch off disconnects the Charging circuitry from the Voltage Boosting circuitry which turns the power off to the USB A Plug out (for the external computer). Charging of the LiPo battery continues.

### Cautions

- Live exposed electronic components
- The board may get hot when supplying large loads
- Potential short circuit or electric shock, especially if device gets wet when placed outdoors for solar power collection